



Quality, strength and efficiency





Niels Jørgen Bønløkke
Estate Owner, Lyngbygaard, Denmark

"Here at "Lyngbygaard" we have a traditional plant production with grain, canola, peas and grass seed. We have about 370 hectares. Last year we invested in a new grain installation, here at this farm. We chose Sukup Europe A/S as supplier of 3 silos of 1000 tons each and a Sukup mobile dryer. We of course examined the market for silos and driers. We chose Sukup Europe A/S because we felt they would be the best company for this job. We agreed to make the project a turnkey contract. We have been operating the installation for 2 years now and it has worked perfectly. We had a few problems last year before we knew how to operate the installation but now we know exactly how to operate it and it just works. The grain coming out of the silo is fine and evenly dried and has a good commercial value. If we had the chance we would not change anything at all. We are very pleased with the colour of the silos which has given many positive reactions because they become a natural part of the surroundings even though they are quite big."

Hans Heinrich Emken
Farmer, Barmissen, Germany

"We run 650 hectares in total and 230 here on this farm. We grow winter barley, winter wheat and winter canola here but only one type of crop every year. Therefore it is very important that we can handle and store the crop directly on site. We wanted to build a new installation and asked our adviser about the different possibilities. The adviser stressed the importance of buying an installation that was easy to handle because the distance between this farm and our main farm is quite long. In the winter of 2012 I got in touch with Uwe Kahl, who presented this installation for us. Uwe Kahl planned everything and promised me that the installation was ready for operation on June 30 – and it was. That's why we chose the solution from Sukup Europe A/S via Uwe Kahl. We need to leave this farm as soon as the combine has finished harvesting and the crops have been filled into the silo. We bought the installation from Uwe Kahl and are very satisfied with the service and installation. We can keep our crops in the silo until we find the right time to sell it."



Simon Harrison
Partner at E.S. Harrison & Sons, Lincolnshire, England

"We were looking to increase our storage capacity with a more efficient system than our current on floor storage and we only had a limited amount of space in the preferred location for the new store. We chose to use a Sukup Europe A/S 1000 tonne stirrer silo as the ideal cost effective solution to our needs and this has proven to be a very efficient cost effective drying and storage system that requires little labour involvement. We have received very good service from Sukup Europe A/S from the initial planning stage right through to the present. We would definitely make the same choice again should we need extra storage in the future."



Quality, strength and efficiency



SILOS AND EQUIPMENT

Quality, strength and efficiency
– a silo for your specific project...





Standard equipment for the Sukup silos

- Big inlet with lid at the top of the silo
- Roof ladder with railing and non-skid steps
- Chemical anchor bolts for precise and strong anchoring
- Flexible sealant between silo and foundation
- Large external access door fitted with safety device
- Large external ladder with safety cage
- Internal inspection ladder
- Large roof manhole with safety railing and safety switch



- Sukup quality product from USA
- **EUROCODES approved**
- Silo diameter: 4.6 m – 47,5 m
- Height of the silo wall: 4.5 m – 26.8 m
- Capacity from 51 t to 34.720 t of wheat with external stiffeners
- Strong construction
- Designed with regards to the Eurocode
- Grain storage at a low price
- Well-tested construction
- Galvanized steel construction
- Minimum work efforts during filling and unloading
- Spiral staircase and roof ladder
- Rest platform and accessibility that comply with the regulations

The silos are delivered in industrial quality with strong external stiffeners and delivered in sections for easy and quick on-site assembly. The roof is designed in light-weight sections with shaped stiffeners for stiffness and easy assembly.

The silos are extremely strong and can therefore be fitted with catwalks and conveyor systems without the need of additional stiffening. Aeration and drying equipment including floors, fans, roof vents, stirring system, loading and unloading equipment, external level sensors, equipment for temperature monitoring are available options.

To get the best possible aeration, a fully perforated floor can be supplied. The floors are available for either grain or rapeseed. The rapeseed floor can also be used for aerating grain.

To control the storage stability of the grain, temperature monitoring devices are available. The temperature should be measured in different locations and different heights in the silo.





▶ Sizes

Sukup silo program covers many different sizes and for every purpose. Smaller and larger silos than shown in the table are available.

On the back side of this brochure are shown a few examples. Ask us for more information to cover the complete program.

For more details please check www.sukup-eu.com

▶ News

The world's largest stirring silo

Content with stirring 1.616 t.

Diameter 60 feet = 18.24 m.

Height: 14.58 m.

This unique silo comes with 5 stirring augers to ensure a perfect mixing of the dried grain and a homogenous quality of the dried crops.



▶ When the colour matters...

Sukup silos are also available with a painted surface. The hot dip galvanized silo sheets are degreased where-upon they are painted with a durable powder coating.

You may choose between all standard 1.625 RAL colors – this means that we can always adapt the silo project to your specific requirement.

RAL colours:

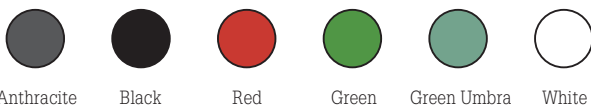

Anthracite

Black

Red

Green

Green Umbra

White





▶ Sukup Stirring System

With the Sukup stirring system you can easily dry and store moist grain in up to 7,5 m grain depth in our outdoor storage bins.

The drying process must be activated as soon as an even grain layer (0.5-1 m) is in the bin.

Warm air is introduced through the fully perforated floor. The lowest grain layer is dried during constant stirring via the 2 – 5 pcs. vertical stirring augers mounted on the horizontal cross-tube. Uniform drying of the grain is achieved by the action of the vertical augers stirring back and forth along the horizontal cross-tube.

The cross tube rotate slowly horizontal around the silo. This forces the down augers to move in and out on the cross tube. The down augers rotate and bring the dried grain from the bottom of the silo to the top. This secures a complete mixing of the crop.

- Drying of storage silos
- Homogeneous drying
- Large capacity
- Simple operation
- Even distribution in the silo
- Minimal maintenance
- Well-proven and patented equipment
- Simple construction and design
- Complete mixing of different grains
- Minimum operational effort required

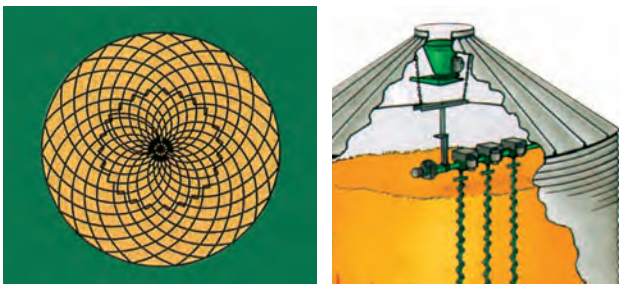

All stirring systems are CE-approved and preassembled and tested at Sukup's own workshop in Hedensted.

▶ Fan and Heating

The fan must be powerful enough to push the air through the grain layer. All heating sources normally used for drying grain in flat storage can be used. This can be oil, gas, hot water etc.

▶ Grain Spreader

In order to ensure an efficient and even distribution of the grain in the silo, a grain spreader is mounted directly below the inlet at the top of the bin. The grain spreader adjustment is infinitely variable to spread the grain evenly and homogeneously in the silo.

▶ Stirring System

The system has a horizontal hanging cross tube with 2-5 down augers, which ensure complete stirring and mixing of grain in the silo. Warm air is supplied while the silo is being stirred, thereby achieving a completely uniform drying of the grain.

The airflow through the grain is increased by up to 33 % because of the stirring. When the grain is stirred, "wet" spots in the bin are avoided. It is also possible to make a perfect mixture of e.g. barley and wheat in the silo.

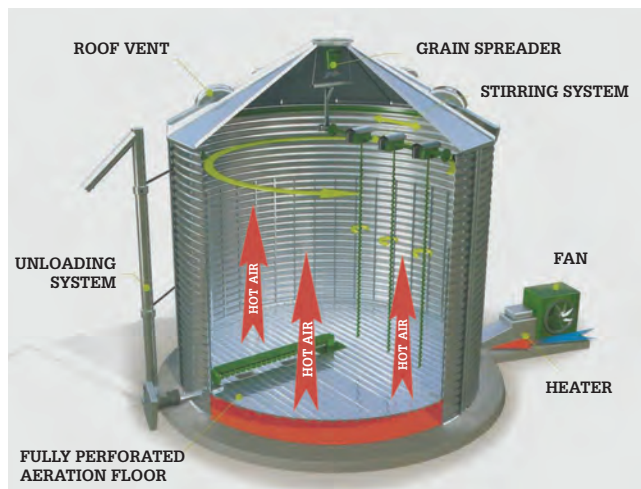



Unloading system

The Sukup unloading system for steel silos consist of an unloading auger with a drive unit, a center sump and a number of intermediate sumps operated by an external handle.

The drive unit is available in 3 different models:

(1) a horizontal drive unit with an extension facility, (2) a 25° incline drive unit or (3) a vertical drive unit to enable vertical unloading directly into a truck or conveyor system.

In addition to the unloading auger, a sweep auger can be mounted which enables the silo to self-empty almost 100 %.

Unloading system ▼

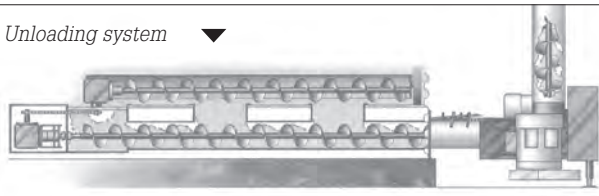

- Flexible construction
- For silos with a diameter from 4.6 to 32.0 m
- Available in 6" (152 mm), 8" (203 mm) and 10" (254 mm) augers
- Capacities up to 35, 65 and 100 tons/h



Sukup HD-Floors

Sukup HD-Floors is delivered with half of the distance between the stiffeners, which in return results in a significantly stronger flooring than traditional aeration floors.

All Sukup HD-Floors is delivered with improved clearing by the fan opening, this result in lesser air resistance and gives a better aeration of the crops.

The HD-Floors can be delivered with Ø2,39mm and Ø1,27mm perforations, suitable for grain and rape seeds.

SuperWave™ Supports ▼

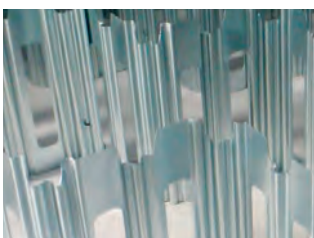

Sukup HD-floor ▼

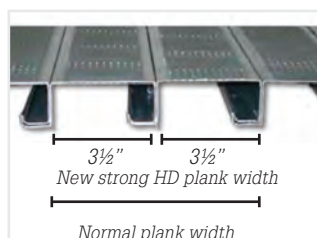

Emptying the silo

- The unloading auger is activated, the centre sump is opened with the remote control. The centre sump leaves a cone of grain in the silo.
- The intermediate sumps are opened with the remote control and the grain above the sweep auger unloads.
- The sweep auger is activated. After only one rotation, the silo is almost 100 % empty.
- Sukup unload systems are as standard delivered with extra big emergency outlet close to the silo center outlet.

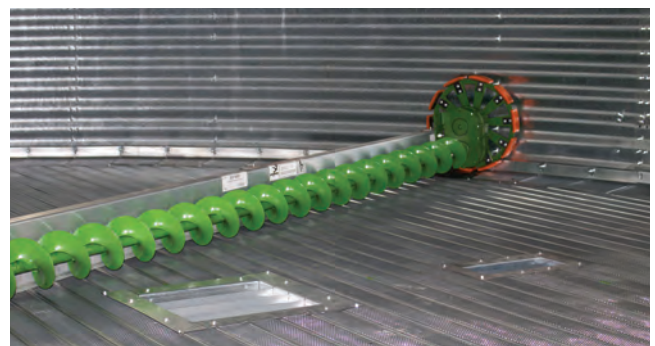

Sukup sweep auger mounted with the standard wheel ▼

The sweep auger can also be delivered with extra reduced speed on the drive wheel, ratio 16:1 ▼

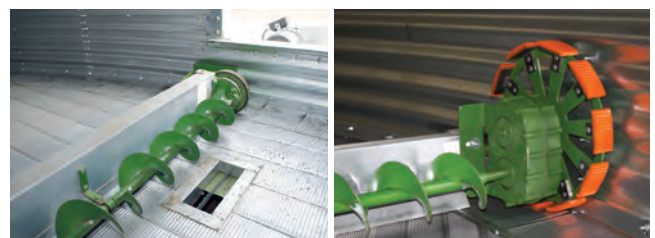

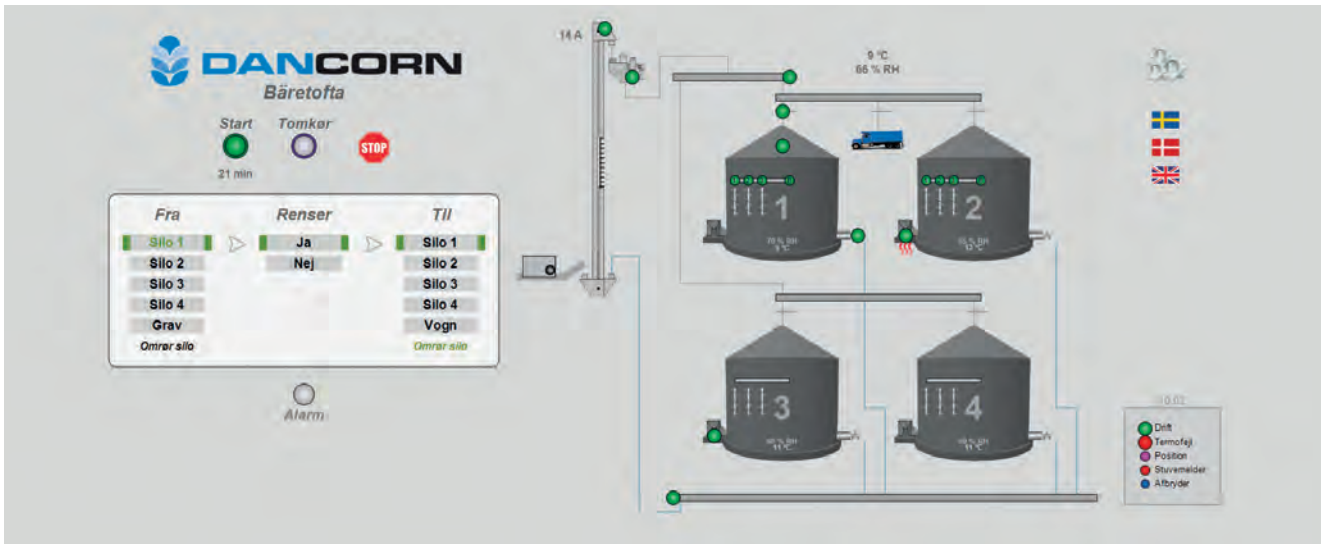

Sukup Control Panels

A good Sukup silo installation includes a control panel adapted to your specific wishes and requirements. Our control panels are available for all project sizes from one single silo to large commercial installations with conveyor system and dryer.

All control panels are tested before delivery in order to make sure that everything works perfectly. All control panels are manufactured according to the Danish legislation.

Sukup control panels:

- Standard control panel for simple installations
- PLC / PC solutions for all silo installations with several silos and conveyor system

Contains starters for fan, grain spreader, stirring system, unloading system and the option to build in a starter for 3 external motors. Including time management of the stirring system and unloading system and the option to control the heating source.



Silo installation with a shed for control panel, distribution board and enough space for a table for crop analysis equipment etc. You can easily inspect the space and intake pit.



Standard control panel for drying silo

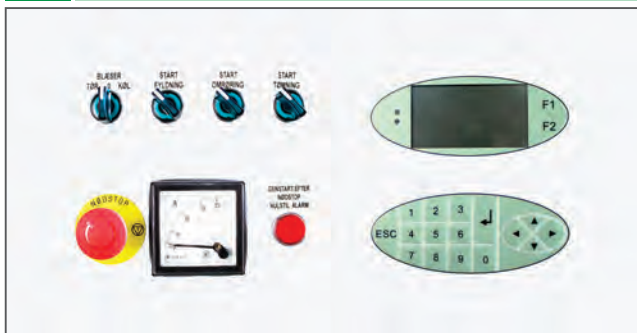

Display with an overview

Touch screen for control panels for Sukup silo installations are available in many sizes adapted to your specific requirements. The large screen gives you a perfect overview of all operations of the silo installation.

PLC / PC control panel for all sizes of silo installations with more silos and conveyor system.

Advanced control panel with touch screen from which the whole installation can be controlled and observed. Including starters for all motors of the installation. Flows are shown and started from the user surface.

Sukup control panels give you opportunity to:

- Go into more detailed overviews showing the control of the intermediate processes of the installation
- Read historic operational data
- Build in e.g. temperature surveillance in storage silos
- Remote control / surveillance of the installation from your office through the Internet
- Get access to troubleshooting, service and updating of the program via the Internet.



Sukup Hopper silo

- Designed and manufactured in the USA
- Diameter from 4.57 to 10,97 m
- Capacity from 59 to 1.730 tons of wheat
- Volume from 78 to 2.277 m³
- 45° / 60° cone shaped hopper

Extra Accessories:

- Strong Roller-Gate outlet slide
- External ladder with safety cage
- Roof ladder to the top of the silo
- Inspection door in the roof sheet
- Inspection door in the sidewall sheet
- Inspection door in the cone sheet

Sukup hopper silo is an excellent wet holding silo for Sukup dryers, truck loading silo and self emptying storage silo.

The hopper silo is made of galvanized sheets in order to extend its lifetime. The hopper silo is delivered with a top ring on which an industrial lid for e.g. conveyor system or catwalk can be mounted.

With its 78 cm the rack-and-pinion steered Roller-Gate outlet slide on the hopper silo ensures sufficient space for mounting conveyor system.



Accessories

Standard roof vents on the roof, industrial lid as well as full level sensors.



Sizes - Silo

Diameter

Volume weight 0.76 ton/m³. With max. 6% compression in higher grain layers. Require refilling after drying.

Silo diameter (m)	7,32	9,14	10,97	12,80	14,60	16,41	18,24
-------------------	------	------	-------	-------	-------	-------	-------

Eave Height 6,73 m

Type	2406	3006	3606	4208	4806	5406	6006
Silo total height	8,93	9,47	10,11	10,64	11,17	11,79	12,34
Max. Content (ton)	246	393	578	803	1069	1391	1751
With aeration (ton)	235	376	554	770	1026	1336	1684
With stirring (ton)	194	302	435	592	770	963	1142

Eave Height 7,85 m

Type	2407	3007	3607	4207	4807	5407	6007
Silo total height	10,05	10,59	11,23	11,76	12,29	12,90	13,46
Max. Content (ton)	283	451	663	917	1220	1581	1985
With aeration (ton)	272	434	639	884	1177	1526	1919
With stirring (ton)	230	359	518	705	917	1163	1379

Eave Height 8,97 m

Type	2408	3008	3608	4208	4808	5408	6008
Silo total height	11,17	11,71	12,35	12,88	13,41	14,02	14,58
Max. Content (ton)	320	510	745	1033	1369	1770	2220
With aeration (ton)	309	493	721	1000	1326	1717	2153
With stirring (ton)	266	416	601	818	1064	1355	1616

Sizes – Hopper silo

Diameter 4,57

Type	1503	1504	1505	1506	1507	1508	1509	1510	1511
Hopper silo total height	7,85	8,69	9,80	10,92	12,03	13,15	14,26	15,38	16,49
Max. content (m ³)	78,2	97,5	116,7	136,0	155,2	174,5	193,8	213,0	232,3
Max. Content (ton)	59,5	74,1	88,7	103,3	118	132,6	147,3	161,9	176,5

Diameter 5,49

Type	1803	1804	1805	1806	1807	1808	1809	1810	1811
Hopper silo total height	8,69	9,52	10,64	11,75	12,84	13,98	15,10	16,19	17,33
Max. content (m ³)	118,4	146,2	173,9	201,6	229,3	257,1	257,1	312,5	340,3
Max. Content (ton)	90,0	111,1	132,2	153,2	174,3	195,4	195,4	237,5	258,6

Diameter 6,40

Type	2103	2104	2105	2106	2107	2108	2109	2110	2111
Hopper silo total height	9,42	10,26	11,37	12,49	13,60	14,72	15,83	16,95	18,06
Max. content (m ³)	169	206,7	244,5	282,2	320,0	357,7	395,5	433,5	471,0
Max. Content (ton)	128,4	157,1	185,8	214,5	243,2	271,9	300,5	329,2	357,9

Above models are examples only. Ask us for more information to cover the complete program.

For more details please check www.sukup-eu.com





FANS, HEATERS AND RADIATORS

Quality, strength and efficiency
– the essential equipment...



Fans

Fans type D

- 7.5-37 kW fan size
- Galvanized – corrosion resistant finish
- High efficiency
- Low noise
- Low power consumption
- Statically and dynamically balanced
- Low self-heating
- Large air quantity
- With suction from right or left side
- Air discharge horizontally or downwards

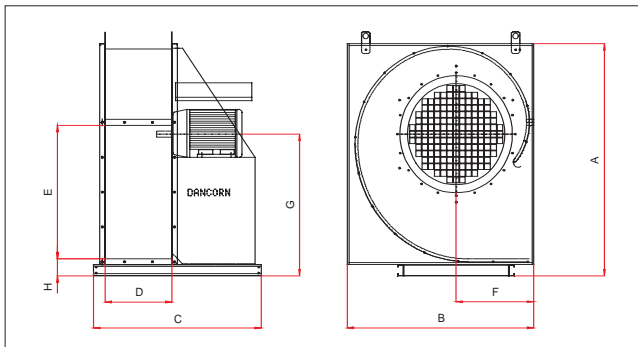
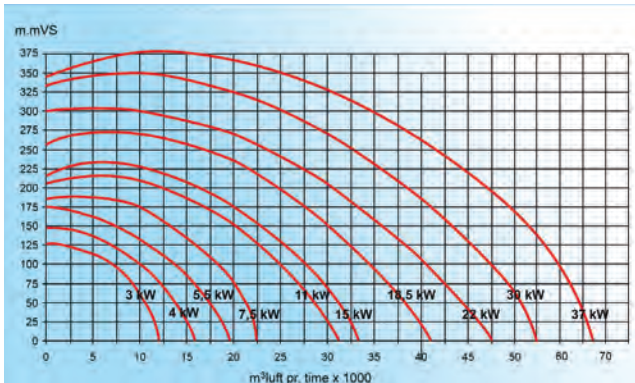

Fans type D

- is developed to provide a large air quantity and the ability to overcome high back pressures. Important qualities for every silo installation, floor storage and aeration system.
- fan impeller is developed using the latest technology resulting in a highly efficient output.
- is made in a modern design, which makes the fan perfect for every installation.

Fans type D is a strong construction made of galvanized sheet to ensure the fan a long life.

The dimensioned sketch shows a fan with inlet from the right.

Output and dimensions for fans provided by the manufacturer.

OUTPUT AND DIMENSIONS FOR FANS:

Type	D10	D15	D20	D25	D30	D40	D50
Motor 1500 rpm. kW	7,5	11,0	15,0	18,5	22,0	30,0	37,0
Motor 1500 rpm. hk	10,0	15,0	20,0	25,0	30,0	40,0	50,0
m3 air by 80 mm w.c.	19.000	27.000	32.000	37.000	44.500	54.000	62.000
m3 air by 120 mm w.c.	16.800	23.000	28.000	33.800	41.500	48.500	57.000
m3 air by 150 mm w.c.	14.000	20.000	25.000	31.200	38.300	46.000	53.000
A mm height	1415	1580	1580	1780	1780	1940	1940
B mm length	1195	1320	1320	1425	1425	1660	1660
C mm width	1180	1210	1280	1245	1305	1400	1400
D mm width	450	480	550	515	575	560	630
E mm height	820	920	920	1040	1040	1100	1100
F mm length	475	535	535	595	595	670	670
G mm height centre	855	980	980	1090	1090	1195	1195
H mm height	90	120	120	120	120	130	130
Inlet	Ø600	Ø700	Ø700	Ø800	Ø800	Ø800	Ø800
Weight incl. electrical motor	211	310	350	420	460	740	760



Heat exchanger type VG-56 for silo drying

▶ Hot Water Radiators

- Safe heating source
- Low operational costs
- No fire protection required
- Hot-dip galvanized
- Long life
- Tested for compressive strength up to 4 bar/ 9 bar - depending on the model.
- Can be used in combination with a straw burner
- Many different sizes available

You get a safe and favorable heating source when connecting a hot water radiator to a central heating system.

If a very high air temperature is required two radiators can be connected in series. For example twin radiators can be mounted on a continuous flow mobile dryer.

The quoted heating outputs are approximate due to the different air quantity, pump size, pipe dimension, pipe length etc.

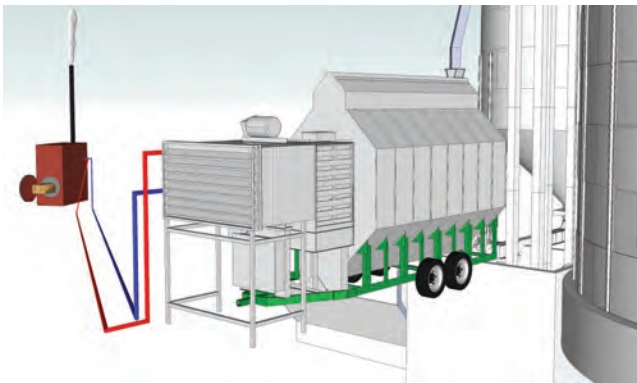

OUTPUT AND DIMENSIONS OF THE HOT WATER RADIATOR:

Calorifier Type	Output (kW)	Dimension (mm)		Weight (kg)	Pumpsized (l/min)	Supply flow temperature (°C)	Airflow (m³/h)
		Height	Width				
VG-34	47	700	750	150	76	90	10.000
VG-36	70	1.050	750	240	114	90	10.000
VG-44	63	700	1.000	230	100	90	10.000
VG-46	95	1.050	1.000	305	152	90	10.000
VG-54	78	700	1.250	250	126	90	10.000
VG-56	122	1.050	1.250	375	190	90	10.000
VK-500	500	1.165	2.400	-	500	95	28.000
VK-600	600	1.500	1.580	-	500	95	35.000
VK-750	750	1.165	2.400	-	500	95	45.000
VK-900	900	2.000	2.000	-	500	95	56.000

Calculated from the parameters above.



Mobile oil heaters

Suitable for:

- Grain drying
- Room heating
- Defrosting – frost protection
- Drying out after cleaning the stables
- Pre-heating of seed potatoes

Accessory package with chimney (2 m), rain cover and filter package.

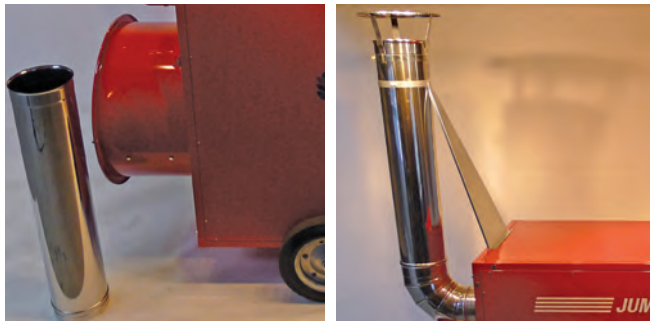

OUTPUT AND DIMENSIONS FOR OIL HEATERS:

Type	Brutto output Kcal / h	Brutto output kW / h	Net output Kcal / h	Net output kW / h	Air output consump m ³ / h	Tank capacity Litre	Fuel Kg / h	Weight Kg	Length mm	Width mm	Height mm
SE120	27.534	32	23.294	27	1.150	42	2,70	48	1215	440	670
SE200	47.318	55	42.350	49	2.000	65	4,64	80	1435	555	940
SE300	73.119	85	63.979	74	3.300	105	7,17	110	1740	690	1025
PH400	94.616- 64.533	110 - 75	85.155- 57.452	99 - 66	5.500	135	9,27- 6,33	149	1840	770	1220
Jumbo110	94.999	110,46	88.159	102,51	9.000	-	8,74	200	1.765	800	1.214
Jumbo145	124.455	144,72	115.992	134,87	12.000	-	11,45	254	1.905	890	1.354
Jumbo185	159.563	185,54	147.117	171,07	13.000	-	14,68	270	2.013	912	1.414
Jumbo235	202.715	235,72	186.498	216,86	17.000	-	18,65	351	2.245	982	1.584
Farm110	94.999	110,46	88.159	102,51	8.500	-	8,74	122	1.110	950	768
Farm145	124.455	144,72	115.992	134,87	11.000	-	11,45	158	1.220	1.080	838
Farm185	159.563	185,54	147.117	171,07	12.000	-	14,68	163	1.324	1.140	858
Farm235	202.715	235,72	186.498	216,86	16.200	-	18,65	233	1.514	1.310	938

Accessory package with chimney (2 m), rain cover and filter package.



Indirect oil heater type OKLIMA

Our oil heater type Oklima has indirect heating, at which the heat emits to the air via a heat exchanger while the damaging products from the incineration are lead through the chimney.

Fuel oil, diesel oil or petroleum can be used as fuel for indirect oil heaters. Oil heaters require 230/440 V connection.

The heater can be controlled manually or by means of an external signal from a hygostat, thermostat, timer or dryer control. The heater can be supplied with oil from the built-in tank (RS heaters) or be connected to an external tank.

Our indirect oil heaters type Oklima are equipped with DANFOSS controls, oil pump and a stainless steel combustion chamber in order to ensure the best operation and long life.





GRAIN CLEANING AND CONVEYOR SYSTEMS

Quality, strength and efficiency
– the individual solution...





Project drawing

▶ Transportation of grain is logistics

We take our starting point in your requirements during the planning of the grain transportation – both in new installations and when an extension of an existing installation is needed.

We have no preference towards our suppliers – therefore we always offer unique solutions from different suppliers.



SKANDIA
ELEVATOR





Ready installation

▶ A conveyor system that fit to the request

Our conveyor system is made by standard elements, which can be easily adapted to every installation. They are characterized by large capacity in spite of small external dimensions, quick and easy assembly, because all connections are bolt flanges and with an effective use of the transportation length.

- Galvanized corrosion resistant finish
- Easy assembly
- Long life
- Easy adaption of elevator height
- Capacities from 20 - 600 t/h
- Low operational costs
- Superior quality
- Easy service

Our conveyor systems are perfect for vertical transportation of grain, peas, canola/rape seed, pellets, powder, mixed feed etc. They are characterized by long durability and reliability and by a low power consumption compared to the output.



▲ Service platform and ladder with safety cage on elevator pipe for free-standing bucket elevator.

▶ Belt conveyor for flat storage

With capacities from 20 to 600 t/h we can deliver the best belt conveying solution.

Our belt conveyors can transport the material both ways and with 30° inclination – however with reduced capacity. The belt conveyor is suited for careful transportation of most materials.



▶ Advantages

- Modular system offering flexible solutions based on standard components
- Low power consumption
- Safe and clean conveying
- Belt conveyor with 60 and 80 t/h galvanized for outside assembly
- One-way or two-way conveying

▶ Options

- Tripper carriage which can be moved on the belt conveyor length in order to discharge on both sides of the belt
- Inlet which can operate on the conveyor
- Cover and dust guard below belt
- Speed guard for belt speed
- Several hoppers on same belt
- Wiper to clean the belt

Cleaning and grading

Proper cleaning and grading generally increases quality, reduces wear of mechanical transport systems, improve storage, increase feed quality and raise the sales value of your crop.

Sukup Europe offers standard and customized solutions for cleaning and grading.

Below are some solutions that will ensure your crop quality.

DC Remover - aspirator

A "DC Remover" clean the crop for dust and other light impurities.

The compact dimension makes it easy to implement into the conveyor system.

The price is very attractive and the "DC Remover" is available for capacities up to 150 t / h.

DC Remover ▼



KDC 4000/8000 Drumcleaner

With a KDC drumcleaner you get the features from the built-in aspiration as well as a good precleaning for large and small impurities.

Also features grading ability of malting barley and seeds. A compact design with a capacity up to 80 t / h.



PULCO Aspirator

OMEGA Universal Cleaner

PULCO Aspirator

A Pulco aspirator features cleaning of different crops for dust and light impurities.

It is through its heavy design suitable for larger installations and features the best possible aspiration using its built-in spreading device.

It comes with a capacity up to 300 t / h.

SIGMA Planet Drumcleaner

The SIGMA cleaner is an industrial vertical drum cleaner in combination with an industrial aspiration.

The low noise level and powerful design are suitable for large operations requiring both good pre-cleaning and grading at high capacity.

Capacity up to 220 t / h.

OMEGA Universal cleaner

The OMEGA cleaner is a high quality cleaner which in combination of separate aspirator module and a number of moving sieves guarantee the best quality of both precleaning and fine cleaning.

It features size separation for good quality seed and malting barley.

Precleaning capacity up to 300 t / h.

Fine cleaning capacity up to 50 t / h.



KDC 4000/8000 Drumcleaner





GRAIN AUGERS

Quality, strength and efficiency

– augers and transportation for your crops...





The incredible grain auger...

The MKX auger is supplied with a practical mechanically driven hopper to dump the grain in and a wide transport wheel kit that ensures a stable working situation.

The height of the auger is easily adjusted by one or two hydraulic cylinders.

- Canadian high quality auger with the world's largest capacities
- Well tested construction
- For tractor PTO
- Suited for filling large grain stores and outside bins
- Mobile – can be used on several farms
- Low operation expenses

Capacity

MKX 80:	up to 110 tons wheat/hour (8" = 203 mm)
MKX 100:	up to 160 tons wheat/hour (10" = 254 mm)
MKX 130:	up to 280 tons wheat/hour (13" = 330 mm)
MKX 160:	up to 550 tons wheat/hour (16" = 406 mm)

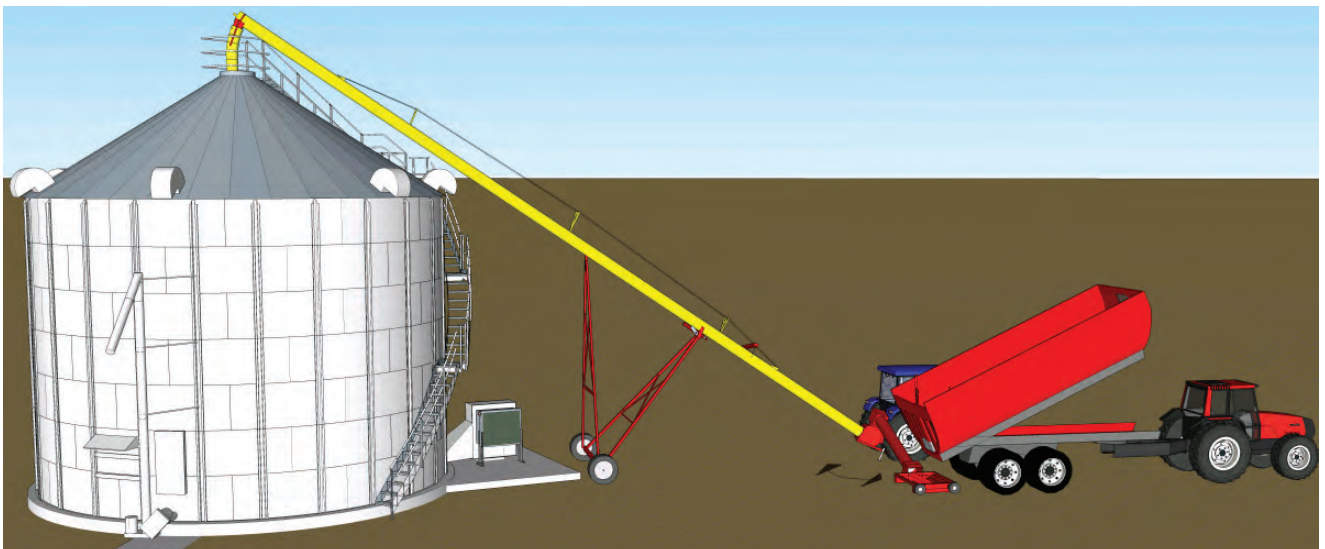



▶ MKX auger

TYPE	LENGTH (m)	EFFECT PTO-hp	DIMENSIONS IN MM (Lowest/highest)		
			A	B	
MKX 80 X 71	21,5	50	3800 / 14140	10200 / 8250	
MKX 100 X 63	18,9	60	3500 / 12300	7800 / 9100	
MKX 100 X 73	21,9	70	3800 / 14400	8700 / 10800	
MKX 100 X 83	24,9	80	3500 / 16500	9800 / 12900	
MKX 130 X 74	22,2	130	3500 / 12300	7800 / 9100	
MKX 130 X 84	25,2	140-160	3800 / 14400	8700 / 10800	
MKX 130 X 94	28,2	150-170	3500 / 16500	9800 / 12900	*
MKX 130 X 114	34,2	170-190	3800 / 14400	8700 / 10800	*
MKX 160 X 85	25,5	180	3300 / 10800	6500 / 7800	*
MKX 160 X 105	31,5	210	3500 / 12300	7800 / 9100	*
MKX 160 X 125	37,5	230	3800 / 14400	8700 / 10800	*

Complete auger incl. wide undercarriage with wheels, swing hopper and PTO.
Excl. flexible outlet.

*) Not standard stock item - longer delivery time must be expected.



Dimensions for MKX augers ▼

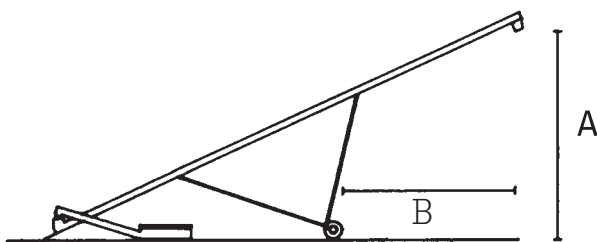

▶ Accessories for MKX auger

- Flexible outlet spout in poly material: 8-10", 5 parts, l: 900 mm
- Flexible outlet spout in poly material: 13", 5 parts, l: 1250 mm
- Flexible outlet spout in poly material: 16"
- Cone shaped special outlet Ø160-Ø300 for 6", 8", 10" & 13" outlet





▶ Strong mobile auger

- Flexible
- Canadian high quality auger with high capacity
- For electrical motor or tractor PTO drive
- Suited for filling large grain stores and outside bins
- Value for money

▶ Capacity

Auger Diameter	15° Incline	30° Incline	40° Incline
8" (203 mm)	70	53	45
10" (254 mm)	120	92	78
13" (330 mm)	160	120	104

Capacity may vary due to the protection net.

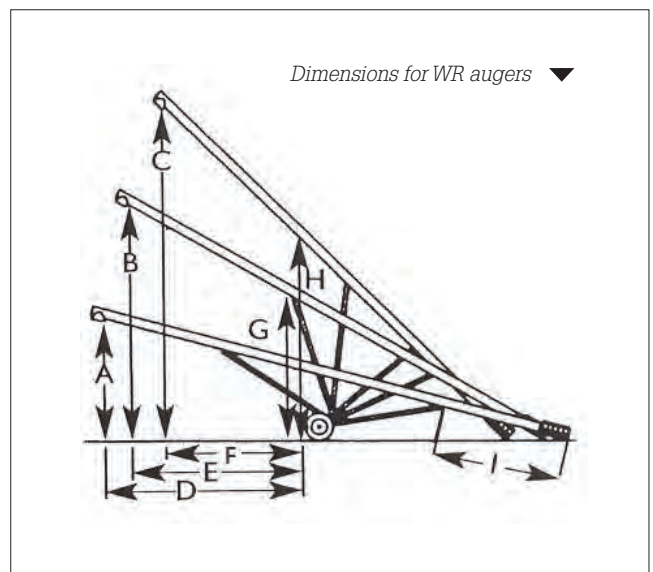

Length	A	B	C	D	E	F	G	H	I
26' / 8,0 m	1950	3840	5450	3270	2870	2200	2350	3440	2080
31' / 9,5 m	2330	4590	6530	4170	3640	2810	2680	3890	2330
36' / 11,0 m	2740	5270	7550	4930	4320	3390	3040	4350	2700
41' / 12,5 m	2910	6130	8680	5670	4960	3840	3490	4960	3090
51' / 15,5 m	3610	7600	10640	7020	6130	4810	4300	6040	3890
61' / 18,5 m	3540	8610	12460	8310	7400	5770	5220	7370	4910
71' / 21,5 m	3890	10030	14290	9620	8540	6840	5970	8360	5600

The auger is delivered unassembled in a galvanized transportation frame.



▶ **WR auger**

▶ **WR inlet hopper options**



▶ **WR electrical motor or PTO-operated**



▶ **Outlet and support wheel**

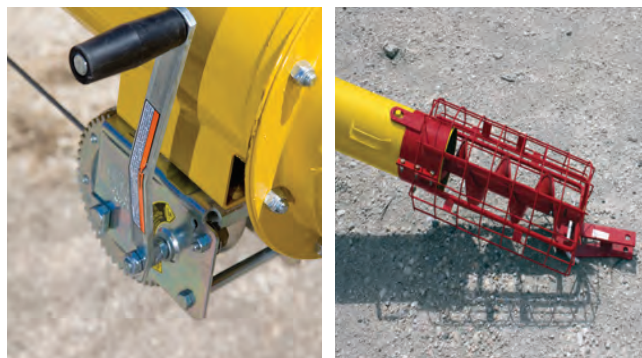

TYPE	DIAMETER	LENGTH	MOTOR
WR 80x26	8" (203 mm)	8,0 m	5,5 kW
WR 80x36	8" (203 mm)	11,0 m	7,5 kW
WR 80x41	8" (203 mm)	12,5 m	7,5 kW
WR 80x51	8" (203 mm)	15,5 m	11,0 kW
WR 80x61	8" (203 mm)	18,5 m	11,0 kW
WR 80x71	8" (203 mm)	21,5 m	15,0 kW
WR 100x31	10" (254 mm)	9,5 m	11,0 kW
WR 100x41	10" (254 mm)	12,5 m	15,0 kW
WR 100x51	10" (254 mm)	15,5 m	18,5 kW
WR 100x61	10" (254 mm)	18,5 m	18,5 kW
WR 100x71	10" (254 mm)	21,5 m	22,0 kW
WR 130x31	13" (330 mm)	9,5 m	18,5 kW
WR 130x36	13" (330 mm)	11,0 m	22,0 kW
WR 130x41	13" (330 mm)	12,5 m	22,0 kW

Accessories for WR augers

Support wheel kit for 8", 10" & 13" WR

Cone shaped special outlet Ø160-Ø300 for 6", 8", 10" & 13" outlet

Big poly hopper. Height x diameter 50 cm x 125 cm

Hopper 35 gr. for 8", 10" & 13" WR 92X92 cm

PTO kit for WR 80x51 and smaller

PTO kit for WR 80x61 and larger

Flexible outlet spout in poly material: 8", 10" & 13"

Delivered with electrical motor and operation box.

**) Not standard stock item - longer delivery time must be expected.*



Cost-efficient auger with large capacity

A UT auger consists of one basic section (A) with outlet spout and drive unit, extensions (B) available in 3 different lengths and lower section with inlet basket or inlet hopper (C).

TYPE	MAX. CAPACITY			
	0°	15°	35°	45°
6" - 152 mm	34	29	22	18
8" - 203 mm	60	51	39	33
10" - 254 mm	102	87	66	56
13" - 330 mm	162	138	105	89

Capacity may vary due to the protection net.

6" (152 MM) AUGER	MOTOR SIZE
Auger type UT 6" x 5,0 m	1,5 kW
Auger type UT 6" x 6,5 m	2,2 kW
Auger type UT 6" x 8,0 m	3,0 kW
Auger type UT 6" x 9,5 m	4,0 kW
Auger type UT 6" x 11,0 m	4,0 kW
Auger type UT 6" x 12,5 m	5,5 kW
Auger type UT 6" x 14,0 m	5,5 kW
Auger type UT 6" x 15,5 m	7,5 kW
10" (254 MM) AUGER	MOTOR SIZE
Auger type UT 10" x 5,0 m	3,0 kW
Auger type UT 10" x 6,5 m	4,0 kW
Auger type UT 10" x 8,0 m	5,5 kW
Auger type UT 10" x 9,5 m	7,5 kW
Auger type UT 10" x 11,0 m	7,5 kW

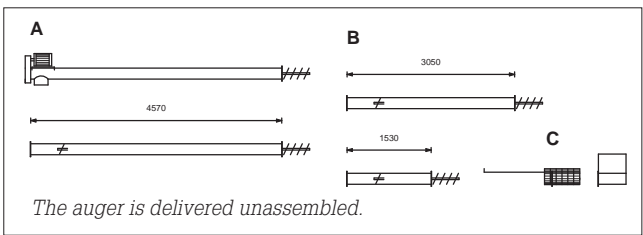

The auger is delivered unassembled.

The UT augers are delivered with motor mount, pulley, capacity regulation, bearing for auger fighting, protection screen and mounting fittings.

8" (203 MM) AUGER	MOTOR SIZE
Auger type UT 8" x 5,0 m	3,0 kW
Auger type UT 8" x 6,5 m	3,0 kW
Auger type UT 8" x 8,0 m	4,0 kW
Auger type UT 8" x 9,5 m	5,5 kW
Auger type UT 8" x 11,0 m	5,5 kW
Auger type UT 8" x 12,5 m	7,5 kW
Auger type UT 8" x 14,0 m	7,5 kW
Auger type UT 8" x 15,5 m	11,0 kW
Auger type UT 8" x 17,0 m	15,0 kW
Auger type UT 8" x 18,5 m	15,0 kW
13" (330 MM) AUGER	MOTOR SIZE
Auger type UT 13" x 6,5 m	15,0 kW
Auger type UT 13" x 8,0 m	18,5 kW
Auger type UT 13" x 9,5 m	18,5 kW
Auger type UT 13" x 11,0 m	22,0 kW
Auger type UT 13" x 12,5 m	22,0 kW

*) Not standard stock item - longer delivery time must be expected.

Accessories for UT augers

Flexible outlet spout in poly material: 6"	Length 90 cm 5-part
Flexible outlet spout in poly material : 8-10"	Length 90 cm 5-part
Flexible outlet spout in poly material: 13"	Length 125 cm 5-part
Wire strengtheners for 6", 8" & 10" UT augers	
Extra mounting fittings for 6", 8", 10" & 13" UT	
Big poly hopper	Height x diameter 50 cm x 125 cm
Big poly hopper for 13" auger	
Handy steel hopper with flight supp. bearing for 6", 8" & 10" auger	
Lid for 6" & 8" inlet hopper Ø200	
Lid for 10" inlet hopper Ø250	
Cone shaped special outlet Ø160-Ø300 for 6", 8", 10" & 13" outlet	
Inlet hopper for auger screw foot with supp. bearing for 6", 8" & 10" auger	

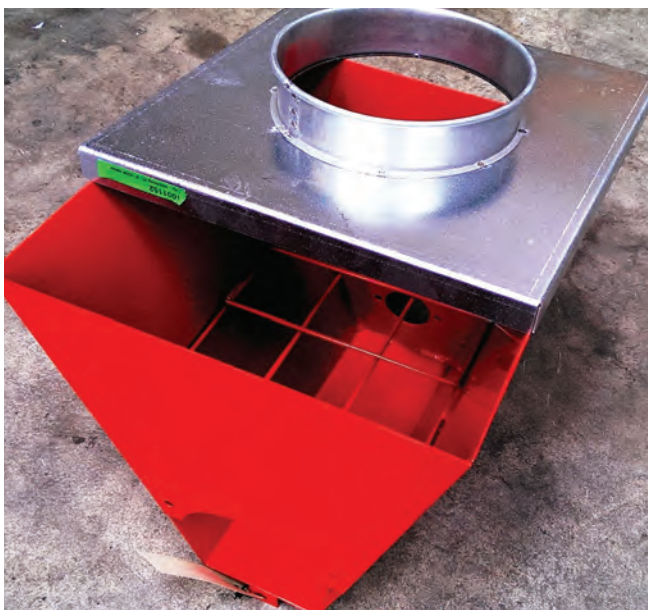
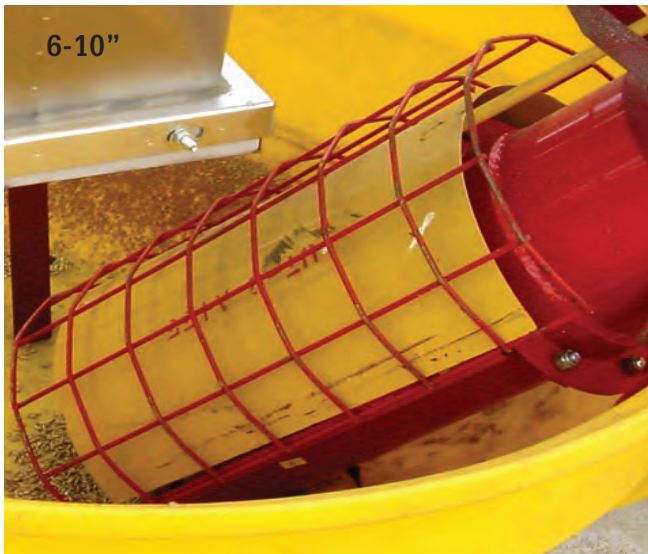



Type B-16 to be mounted on the rear of your wagon

With the Westfield auger for grain and fertilizers on your wagon, you can easily and quickly handle large quantities of grain and fertilizers. The auger is mounted quickly with only one assembly bolt and without use of any tools.

Fold easy and quick to transport position incl. hydraulic motor, electric operated start/stop function mounted at the end of the outlet tube.

The auger is delivered incl. remote control.

Capacity:

25 - 30 t/h

Dimensions:

The length in working position is 4.7 m.

The pipe diameter is 6" (152 mm)



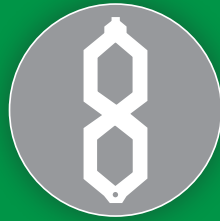

DRYERS

Quality, strength and efficiency
– the most flexible and efficient dryers on the market...





▶ Mobile Continuous flow dryer

- Capacities up to 45 t/h
- Plug and play, delivered ready for operation
- Suitable for drying of all crop types
- Flexible
- Easy to clean
- Simple and automatic operation
- Future-proof – can be extended to Stack dryer

The dryers are delivered with QuadraTouch-/QuadraTouch Pro user control systems dependent on the model ▼



▶ What makes the difference?

- The only dryer on the market with quad metering roll system to ensure a homogenous and careful drying.
- The most advanced and user-friendly controller provides trouble-free, no-hassle operation of the dryer.
- The drying process is controlled by measuring the actual water content.
- Large savings due to the low installation and operational costs.
- Grain exchangers in the stack dryer ensure optimum quality.
- Option: radiator for additional energy saving.



Traditional Dryers

- All grain moves down the column at the same speed, resulting in over dried grain next to the inner wall.
- Metering roll speed varies depending upon an averaging of kernel temperature.
- One metering roll per side.

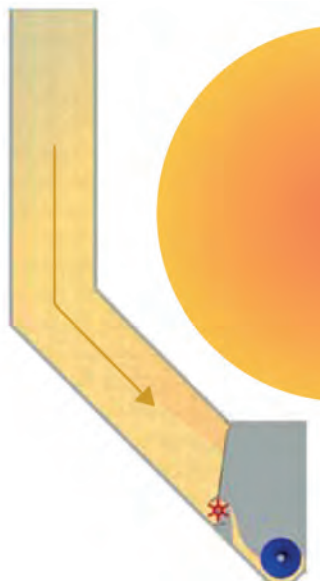

Sukup Solution™

- Hotter, drier grain next to the inner wall moves down the column faster due to the Quad (4) Metering Rolls.
- Metering roll speed varies depending upon the actual moisture content of the discharged grain.

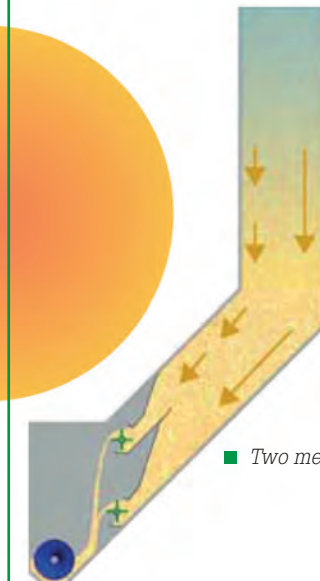

- Two metering rolls per side.



▲ DC 12 mobile dryer with axial fan

▶ Stack dryer

- Capacities greater than 100 t/h
- Suitable for all crops
- Can be delivered as 2 and 3 module dryer
- Each module are delivered pre assembled from factory ready to stack on site
- Same Quad metering roll system as the mobile dryers
- Same QuadraTouch Pro control system as the mobile dryers
- Grain Cross-Over system are standard in stack dryers. This secures an optimal drying process and top grain quality



2 module stack dryers with capacities up to 78 t/h
3 module stack dryers with capacities up to 117 t/h

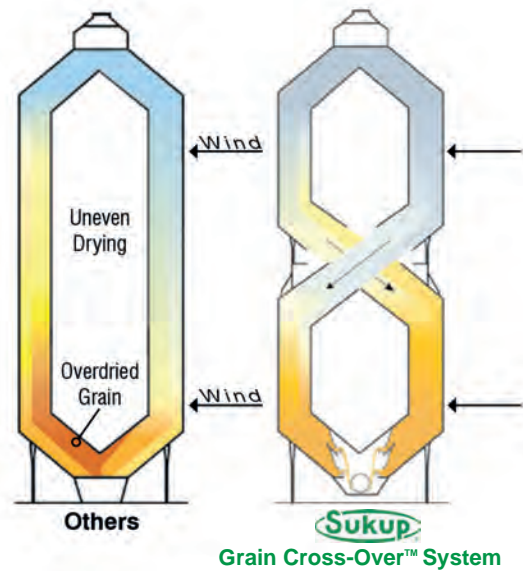

▶ Grain Cross-Over™

- The inner and hotter layer of the grain in the upper module becomes outer, cooler layer in the bottom module due the Cross-Over system
- Helps prevent grain from over drying
- More consistent moisture content

Tower Dryers

Sukup design and delivers a line of commercial Tower Dryers.

Tower Dryer Advantages

- Efficient and simple design
- Large drying capacity, 30 t/h - 200 t/h
- Suitable for drying of grain, canola, corn etc.
- Energy saving
- Heat recovery is a standard feature
- Low noise
- Stainless steel outer screens, nuts, and bolts
- Two clean-out doors per panel in grain exchange section allow for easy removal of debris
- High quality ATEX approved motors
- Heat recovery is standard and ensures an energy friendly drying process
- Quadra Touch control system is user-friendly and ensures an efficient operation of the dryer
- Access doors from the platforms allow easy cleaning
- Maxon burners in industrial quality is standard
- Entry areas in outer screens and reducer cone allow access to the burner area for easy interior cleaning
- Grain turners move the grain from the inside of the column to the outside for more even moisture content and consistent grain temperature.
- Industrial grade inline centrifugal blowers quietly provide high airflow even with vacuum cooling.
- The fan construction and position ensure a low noise operation. The special designed unloading system ensures homogenous unloading of the dryer. Continuous measurement of the water content at the top and at the bottom ensures a more accurate and automatic control of the water content of the crops.
- The fuel ramp is supplied with Siemens and Maxon components and is of course fully modulated for easy adjustment of and equal drying air temperature

Capacities up to 200 t/h



SMS and GSM phone modem

GSM phone modem works with the QuadraTouch™ – controlled and operated through GSM mobile service. If the dryer shuts down, the GSM service will send a message to a predetermined cell phone number and record the error.

You can also get in touch with the dryer and read about dryer status, adjust the moisture, change the unloading speed and adjust temperatures.





FLAT STORAGE

Quality, strength and efficiency
– 60 years of experience obliges...





▶ Floor Storage Silos

- Made of galvanized steel sheets
- Height from 2.00 m to 8.00 m
- Self-supporting construction
- Easy cleaning
- Resists any attack from vermin
- Easy and quick assembly – suited for self-installation
- Solid and flexible construction

A simple, strong construction makes this system easy to install in both existing and new buildings and the system is self-supporting – all the pressure is absorbed by the silo itself. Therefore no demands are made on the ability of the building to withstand pressure.

All the components of each steel silo are delivered in the correct dimensions according to the approved drawings so materials do not need to be adjusted on site.



▲ Plank gates

▶ Post System Walling

- Movable and flexible solution
- Free-standing
- Consists of painted H-iron posts in embedding troughs. Damp-proof wooden panels with reinforced edges are placed between the posts.
- Wall height from 1.8 to 4.2 m



▶ Wooden main air ducts

- Consists of strong frames boarded with veneer sheets in hardwood
- Catwalk above main duct for easy crop inspection
- Bolted directly into an even floor without further foundation and tension rods
- Quick and simple assembly
- Suited for self-installation
- Main ducts width: 92, 122 or 150 cm
- Main duct height: 245, 305 or 366 cm





▶ Half round Side Ducts

- Hot-galvanized sheet metal
- Great mould accuracy and very high support capacity
- Easy assembly on a even floor
- 1.5 - 2.0 mm perforations, round holes
- Favorable for on-floor flat storage solution
- The side duct comes in 3 sizes

The GP side duct with closed or open top is a universal duct suited for all types of crop drying and ventilation.

The GP-900 side duct is suited for duct lengths up to 8-10 m in seed and 10 – 12 m in grain (drying).

The GP-1600 side duct is suited for duct lengths up to 10 – 12 m in seed and 12 – 18 m in grain (drying).



Duct distance during drying: Grain 100 cm. Seed 80 cm

	S-900	S-1600	S-2500
Height	24 cm	32 cm	40 cm
Width	48 cm	64 cm	80 cm
Length	92 cm	92 cm	92 cm
Efficient length	85 cm	85 cm	85 cm

▶ Drive-Over Side Ducts

- Drive-over safe, withstands 10-14 tons of axle pressure
- Quick loading and unloading
- Also for canola and grass seed without hessian
- Suited for self-installation
- Available with embedding troughs
- Slotted or fully perforated surface, - up to 26% open area

During filling of the crops it is possible to drive directly into the flat storage with the vehicle and unload, and afterwards push the crops in place with a front loader.

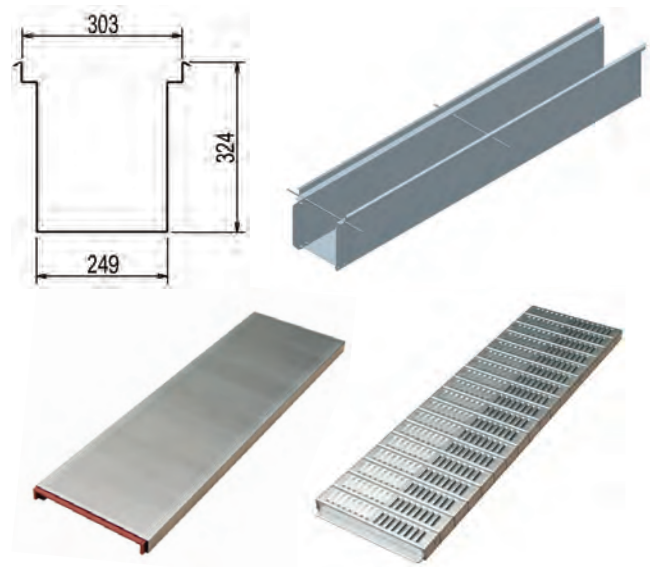

Our special embedding troughs make the task of concrete casting easier as well as making the ducts extremely easy to clean. These troughs are 20, 30 or 40 cm deep and made of galvanized steel. The center distance for grain is approx. 70-75 cm and for seed approx. 60-65 cm.



▶ Flach & Le-Roy Drive-On Floors

- The original Flach & Le-Roy crop drying ventilation systems – 10 years of warranty
- You may dry all kinds of crops
- Excellent air distribution ideal for difficult-to-dry crops
- High-strength, durable floors can withstand 10 tons axle weight
- Simple filling and unloading
- Easy assembly, ideal for self-installation
- Very easy cleaning and large security for clean crops during handling process
- Can be placed on existing concrete floor
- Low build-in height of ready floor

The floor construction comprises high specification kiln dried hardwood boards mounted on pressure-treated bearers providing a highly stable, strong and durable floor. Each top board is separated by a perforated steel mesh enabling excellent air distribution over the entire floor area.

Flach & Le-Roy main air ducts are manufactured using the same high-grade timber as in the floors and designed for maximum air distribution efficiency to ensure that air is delivered precisely where it is needed.

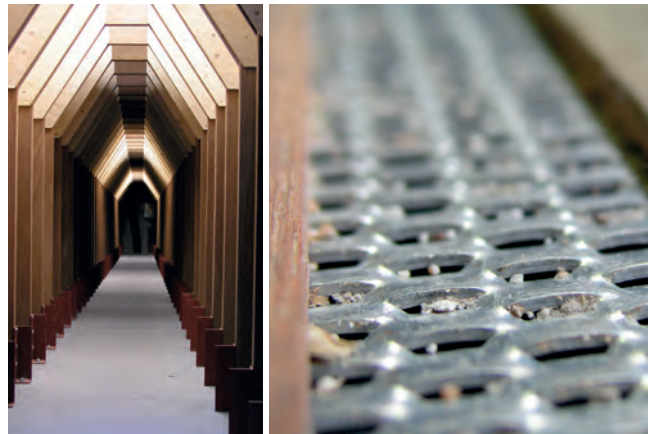

The brochures are subject to printing errors and technical errors.



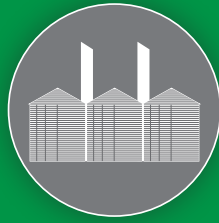

INDUSTRIAL SILO

Quality, strength and efficiency
– when size matters...





Commercial Installations

We have more than 60 years of experience within the line of project engineering and construction of installations for grain handling, storage and conveying.

We offer small and XL projects - and everything in between! Our Project Department ensures the highest quality standards from receiving the order until the installation is ready for operation. The same project manager will follow your project from A-Z.

- An industrial quality silo
- Silo diameter from 10.97 to 47.50 m
- Capacity from 800 t to 53,500 tons of wheat
- Well-tested construction
- External stiffeners provide for maximum strength
- Galvanized steel construction
- Minimum effort required for loading and unloading
- Grain storage without access for birds and animals
- Aeration system
- Optimal use of the developed space
- Stairs and catwalks = safe access
- Designed to meet your demands
- Grain storage at a low price
- Regulation safety devices fitted

Silo unloading

With a sweep auger of highest quality that can empty the silo with a capacity up to 200 t/h.

Can be equipped with different accessories as ex. cleaning brushes.

Accessories

- Temperature monitoring system
- Full/empty sensors
- Sprinkling system

Reinforced Construction

The diameter of industrial steel silos is typically quite large and therefore it might be necessary to divide the roof sheets into more sections. The roof sheets are mounted on strong steel rafters. This means that the load capacity of the roof is increased giving the option to mount heavy equipment like catwalks and heavy conveyor systems above the silo. Furthermore it is possible to mount a large number of sensor cables for temperature monitoring.





# of Rings	9	10	11	12	13	14	15	16	17	18	19	20	21	22	23	24
Eave height	10.08	11.2	12.32	13.44	14.55	15.67	16.79	17.91	19.02	20.14	21.26	22.38	23.5	24.61	25.73	25.85

Model	Total height	Max Content (m ³)	Model	Total height	Max Content (m ³)	Model	Total height	Max Content (m ³)	Model	Total height	Max Content (m ³)
4209	14.00	1427	4809	14.53	1891	5409	15.14	2427	6009	15.7	3038
4210	15.11	1569	4810	15.65	2077	5410	16.26	2662	6010	16.81	3328
4211	16.23	1712	4811	16.76	2262	5411	17.37	2897	6011	17.93	3619
4212	17.35	1854	4812	17.88	2448	5412	18.49	3132	6012	19.05	3909
4213	18.47	1996	4813	19.00	2634	5413	19.61	3367	6013	20.17	4199
4214	19.58	2138	4814	20.12	2820	5414	20.73	3603	6014	21.29	4490
4215	20.70	2281	4815	21.23	3006	5415	21.84	3838	6015	22.4	4780
4216	21.82	2423	4816	22.35	3191	5416	22.96	4073	6016	23.52	5070
4217	22.94	2565	4817	23.47	3377	5417	24.08	4308	6017	24.64	5360
4218	24.05	2707	4818	24.59	3563	5418	25.2	4543	6018	25.76	5651
4219	25.17	2850	4819	25.70	3749	5419	26.31	4778	6019	26.87	5941
4220	26.29	2992	4820	26.82	3934	5420	27.43	5013	6020	27.99	6231
4221	27.41	3134	4821	27.94	4120	5421	28.55	5249	6021	29.11	6522
4222	28.52	3276	4822	29.06	4306	5422	29.67	5484	6022	30.23	6812
4223	29.64	3419	4823	3.02	4492	5423	30.78	5719	6023	31.34	7102
4224	30.76	3561	4824	31.29	4678	5424	31.9	5954	6024	32.46	7393
7209	16.79	4499	7509	17.07	4911	7809	17.35	5351	9009	18.49	7307
7210	17.91	4917	7510	18.19	5364	7810	18.47	5842	9010	19.61	7960
7211	19.02	5335	7511	19.30	5818	7811	19.58	6332	9011	20.73	8613
7212	20.14	5753	7512	20.42	6271	7812	20.70	6823	9012	21.84	9266
7213	21.26	6171	7513	21.54	6725	7813	21.82	7314	9013	22.96	9919
7214	22.38	6589	7514	22.66	7179	7814	22.94	7804	9014	24.08	10573
7215	23.50	7007	7515	23.77	7632	7815	24.05	8295	9015	25.20	11226
7216	24.61	7425	7516	24.89	8086	7816	25.17	8786	9016	26.31	11879
7217	25.73	7843	7517	26.01	8539	7817	26.29	9276	9017	27.43	12532
7218	26.85	8262	7518	27.13	8993	7818	27.41	9767	9018	28.55	13185
7219	27.97	8680	7519	28.24	9446	7819	28.52	10258	9019	29.67	13838
7220	29.08	9098	7520	29.36	9900	7820	29.64	10748	9020	30.78	14492
7221	30.20	9516	7521	30.48	10354	7821	30.76	11239	9021	31.90	15145
7222	31.32	9934	7522	31.60	10807	7822	31.88	11729	9022	33.02	15798
7223	32.44	10352	7523	32.72	11261	7823	32.99	12220	9023	34.14	16451
7224	33.55	10770	7524	33.83	11714	7824	34.11	12711	9024	35.26	17104
10509	19.91	10266	13509	21.62	18030	15609	23.04	21358	Taller eave heights than mentioned in the cart are available in some situations. Model # indicates silo diameter (in feet) and number of rings.		
10510	21.03	11155	13510	22.73	19500	15610	24.16	23031			
10511	22.15	12044	13511	23.85	20969	15611	25.27	24703			
10512	23.27	12933	13512	24.97	22439	15612	26.39	26375			
10513	24.38	13822	13513	26.09	23909	15613	27.51	28047			
10514	25.50	14711	13514	27.20	25378	15614	28.63	29719			
10515	26.62	15600	13515	28.32	26848	15615	29.74	31391			
10516	27.74	16489	13516	29.44	28318	15616	30.86	33064			
10517	28.85	17378	13517	30.56	29787	15617	31.98	34736			
10518	29.97	18267	13518	31.67	31257	15618	33.1	36408			
10519	31.09	19156	13519	32.79	32726	15619	34.21	38080			
10520	32.21	20045	13520	33.91	34196	15620	35.33	39752			
10521	33.32	20934	13521	35.03	35666	15621	36.45	41425			
10522	34.44	21823	13522	36.14	37135	15622	37.57	43097			
10523	35.56	22713	13523	37.26	38605						
10524	36.68	23602	13524	38.38	40075						

The brochures are subject to printing errors and technical errors.



ABOUT QUALITY

There is hardly anything in the world
that some man cannot make **a little worse
and sell a little cheaper**,
and the people who consider price
only are this man's lawful prey.

ABOUT PRICE

It's unwise to pay too much,
but it's **worse to pay too little**.
When you pay too much, you lose a little money
– **that's all**.

When you pay too little,
you sometimes lose everything,
because the thing you bought was **incapable**
of doing the thing it was bought to do.

The common law of business balance
prohibits paying a little and getting a lot
– **it can't be done**.

If you deal with the lowest bidder,
it is well to add something for the risk you run.
And if you do that **you will have enough
to pay for something better**.

– John Ruskin
Engelsk forfatter

Sukup Europe A/S

Quality, strength and efficiency



The company was founded in 1955 at Klejsgaard, when we bought our first combine and the need for grain drying and storage was a reality. Since then, we have endeavored to use our practical experience from our own farm with the latest ideas in our product innovation.

We are today one of the oldest companies within our field. The first 60 years the company was operating under the name DanCorn, and today we are promoted as Sukup Europe. The sales are today both being done through dealers and as direct sale to end-users. Hereby we secure the use of our many years of experience in the development and assembly of grain and seed handling plants.

